

CHAINTRACK DRIVE 6000

TECHNICAL DATA SHEET

January 2021

The ChainTrack Drive (CTD) systems facilitate motion of stage curtains or set pieces on a stage track by means of electric motors.

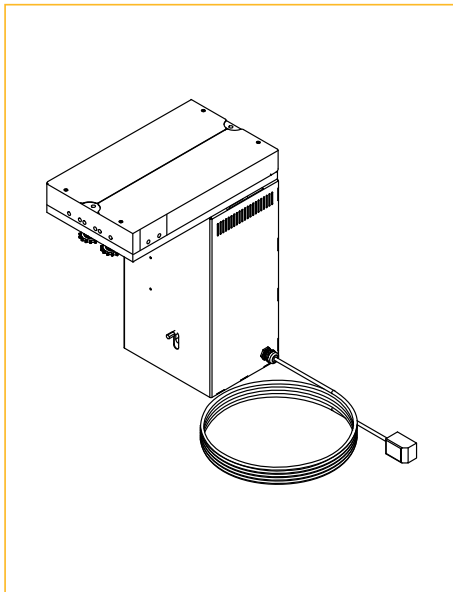

» SPECIFICATIONS

- Equipped with a motor with brake for continuous use (Duty Cycle S1 - 100 %).
- Built up in 2 major parts: Motor Unit with Chain transmission and Control Unit.
- The control unit is independent suspended.
- All connections are made with plugs which makes it easy for installation.
- Equipped with an easy-to-use remote control with open/close switch, fixed speed switch & emergency stop.
- Can be controlled from a lighting console with 3 DMX channels: position - position fine - speed.
- Precision positioning.

» OUTER DIMENSIONS (MM)

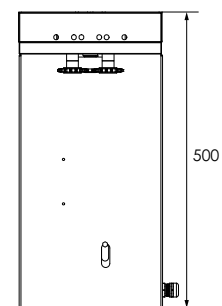
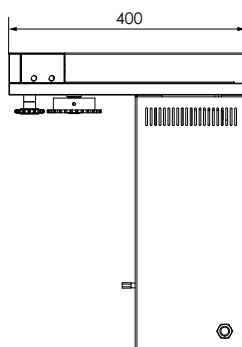
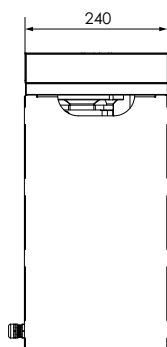

» ELECTRONICAL AND MECHANICAL PROPERTIES

» CTD 6000 • 121 rpm

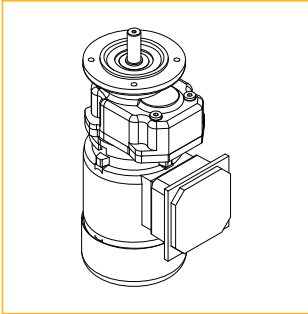

- Motor torque : 59.3 Nm
- Motor speed : 121 rpm
- Maximum chain force : 1394 N
- Chain speed : 0 to 85 cm/sec
- Motor Power : 750 W
- Power in : 3 x 230 VAC +N • 3,6 A
- Power connection : Harting to controll box
- Duty Cycle : S1 - Continuous Duty

» INSTALLATION SPECIFICATIONS

- Power Supply : 1 x 230 VAC +N • 50/60Hz • 16 A
- Power Connection : PowerCON 20A / Schuco
- Power Distribution: Provide a separate differential switch of 30mA for the motor (Motor is driven by a Frequency drive, the RFI filters produce a [leakage current](#))

» SETTING

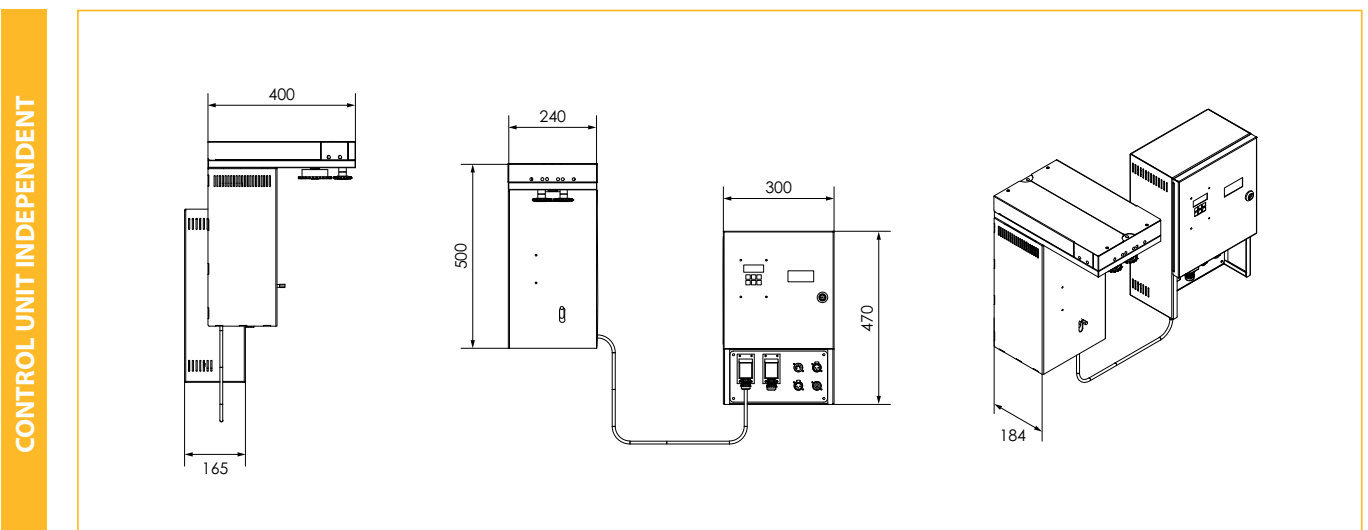

» COMPONENTS (MM)

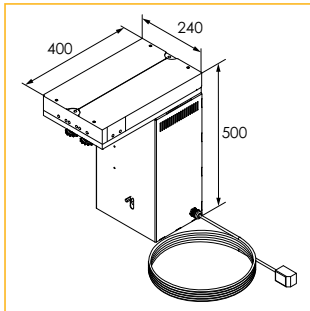

CTD 6000 Motor

Article code	Colour	Info	Weight
8080 0702 7507	Black	750 W • 3 x 230 VAC + N • 50 Hz • 3,6 A • including brake	35 kg/pc

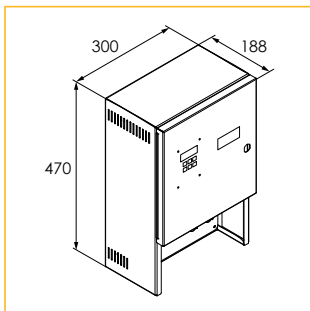

CTD 6000 DMX Control Unit

Article code	Colour	Info	Weight
8080 0750 7507	Black	Including 2 clamps of 75 kg	11.6 kg/pc

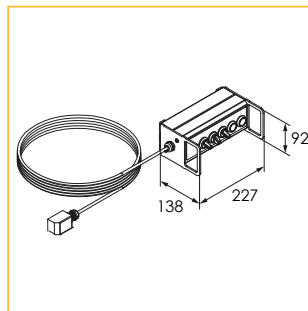

CTD 6000 Remote Unit

Article code	Colour	Info	Weight
8080 0766 7507	Black	With emergency stop 25m cable	4.92 kg/pc

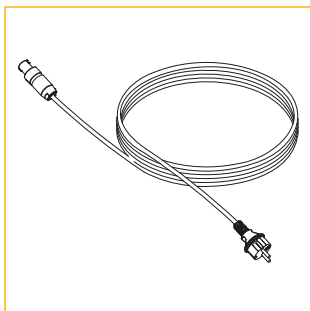

Power Cable

Article code	Colour	Info	Weight
8150 0912 0027	Black	Length : 2m	0.43 kg/pc

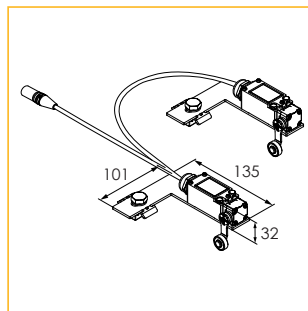

Limit Switch Set

Article code	Colour	Info	Weight
8050 0770 0015	Grey	2 pieces • 25m cable	0.85 kg/pc

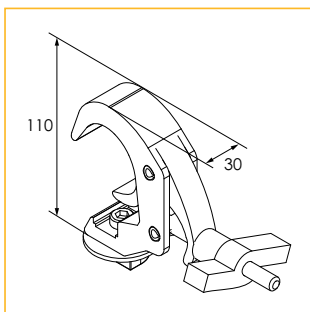

Hook Clamp 100 kg with Channel Nut M10

Article code	Colour	Info	Weight
8080 0680 0007	Black		1.22 kg/pc

» ELECTRICAL WIRING & CONNECTORS

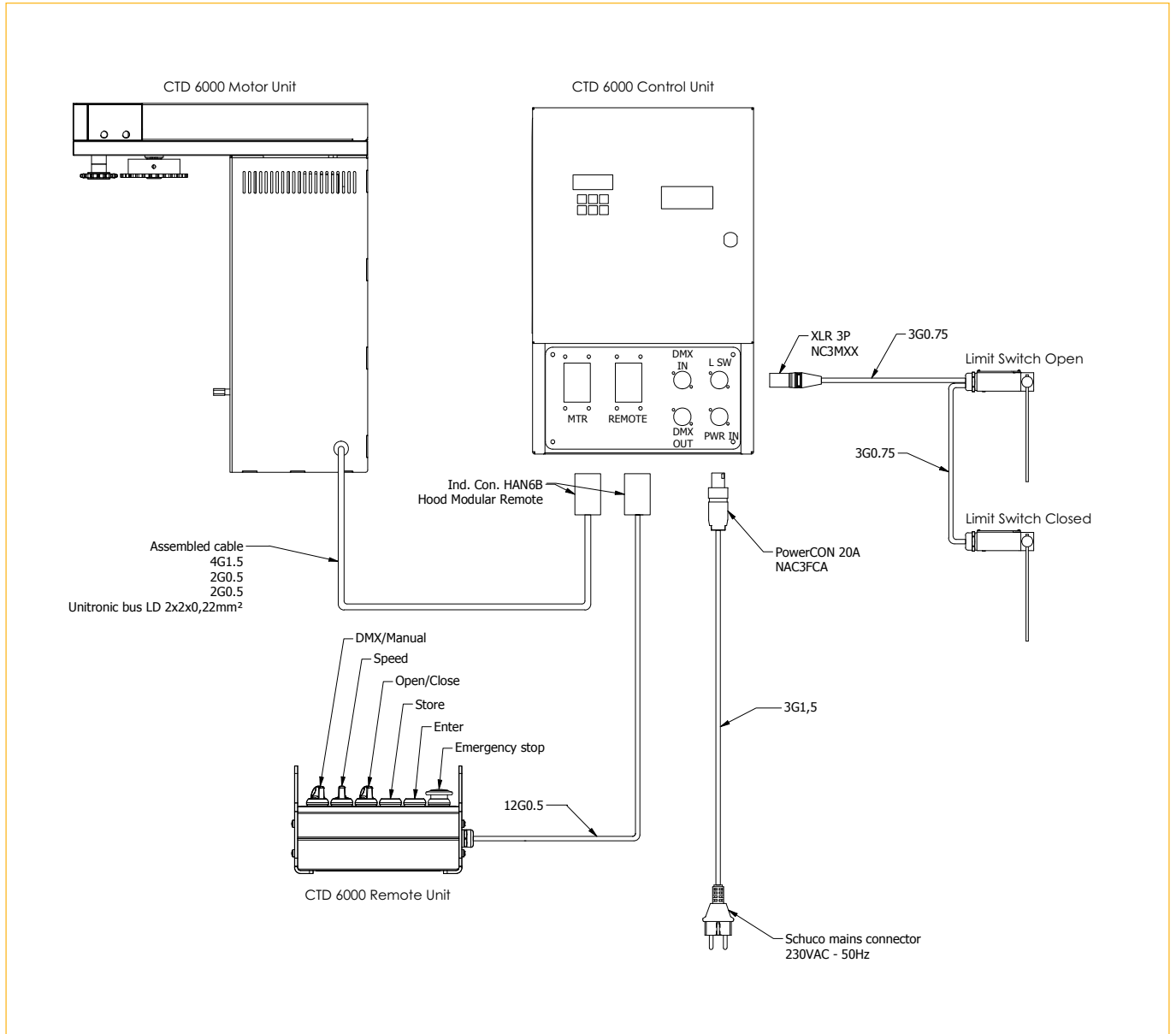

HAVE A GREAT SHOW!
MORE INFO ON WWW.SHOWTEX.COM