

SHOWPIPE

TECHNICAL DATA SHEET

March 2018

The ShowPipe is a sturdier, aluminum version of the H100 track.

» TRACK DIMENSIONS (MM)

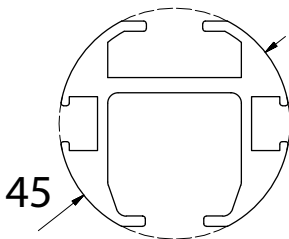

Track weight	1.31 kg/m
Track section max length	6 m
Curved track min radius	0.45 m

» SPECIFICATIONS

ShowPipe is a black anodized extruded aluminum track based on the geometry of the H100. It was designed to slide into our 50 mm aluminum construction tubes. The rails are anodized.

Rails are available in straight lengths or corners of customizable radii. Couplers are available to couple straight as well as curved rails.

Mounting of the profile can be done with any channel nut or bolt that matches the size of the top channel.

A ShowPipe system can be operated:

- Manually: walking along the track or through rope-operation,
- Or automatically: through rope operation with the RTD series motors.

Different types of runners are available to answer a broad range of possible needs, including ball raced runners, scenery carriers, master carriers with brakes and overlap carriers.

» LOAD CAPACITY TRACK

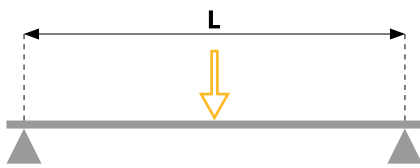

L (m)	Point load (kg)
1	135 kg
2	68 kg
3	49 kg

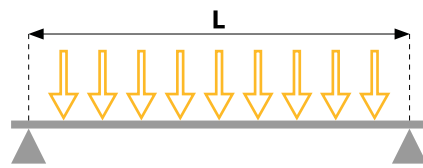

L (m)	Uniformly distributed load (kg/m) • total resulting load (kg)
1	210 kg/m • 210 kg
2	60 kg/m • 120 kg
3	30 kg/m • 90 kg

! The stated load capacities apply to the rail only. The load bearing capacity of the carrying construction (ceiling/truss/...) and all individual mounting accessories must be taken into account as well.

Load capacities have been calculated using Safety Factor 2. Apply the required Safety factor according to the standards pertaining to your application.

» TRACK DIMENSIONS ACCORDING TO CURTAIN SIZE (MM)

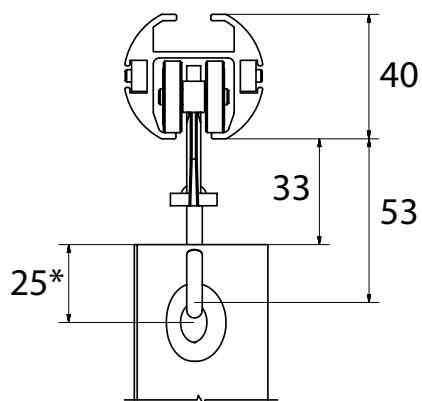

* standard distance for grommet

» RUNNER INFORMATION

Name	Article code	SWL	MIN. RADIUS OF BENDED RAIL
Ball raced runner	8050 0205 0087	8 kg	450 mm
Master carrier	8050 0221 0167	15 kg	450 mm
Scenery carrier	8050 0230 0302	60 kg	450 mm
Master carrier with brake	8050 0221 0197	15 kg	450 mm
Short overlap carrier	8050 0245 0057	15 kg	450 mm
Long overlap carrier set	8050 0246 0167	15 kg	2000 mm
Master carrier for motor control	8050 0228 0167	15 kg	n.a.
Short overlap carrier for motor control	8050 0245 1057	15 kg	n.a.
Long overlap carrier set for motor control	8050 0246 1167	15 kg	n.a.

» ASSEMBLIES

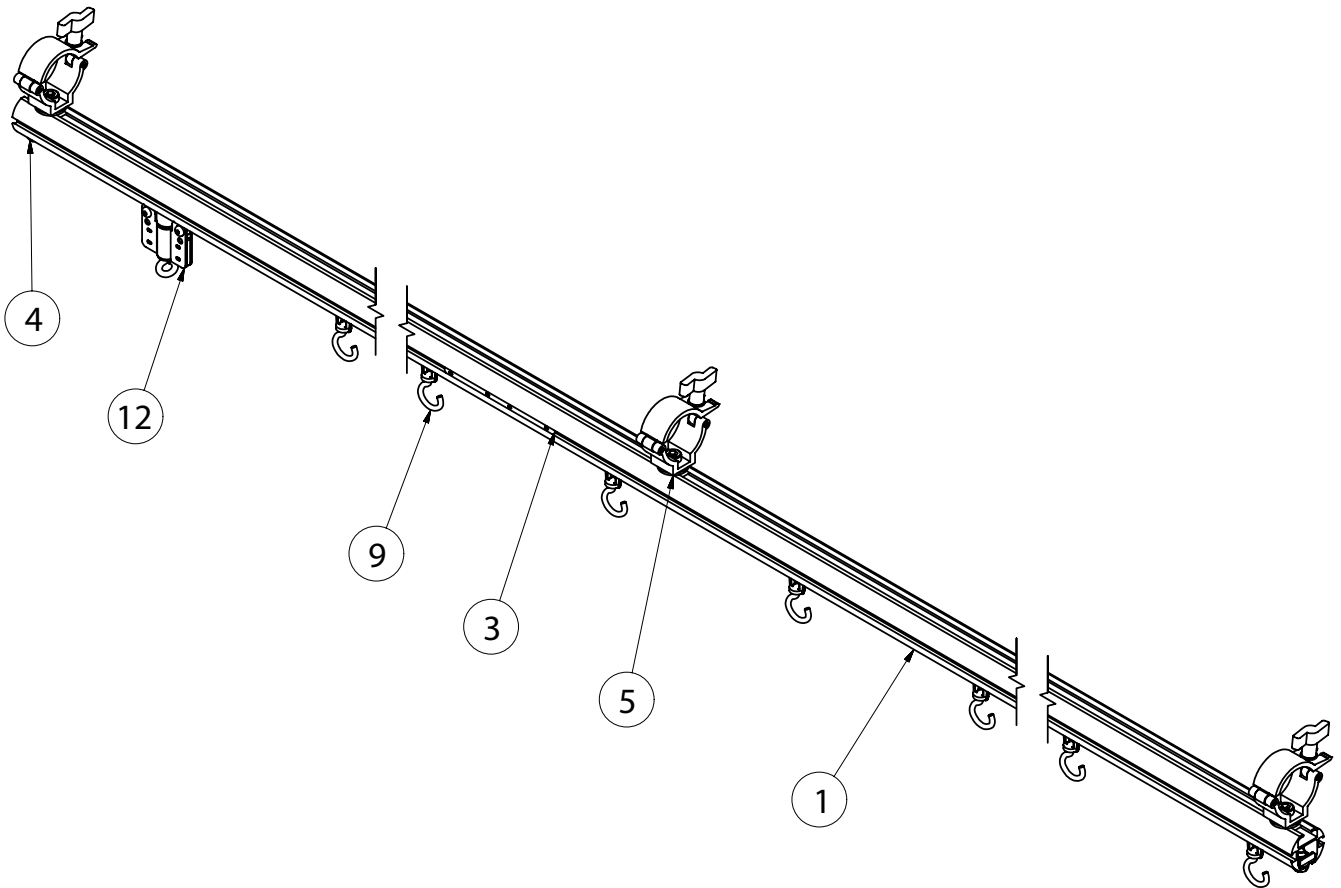

WALK-ALONG OPERATION

This is the most basic installation of the ShowPipe system. The curtain is pulled along the rail to its required position. Optional braked master carriers make manual positioning more accurate.

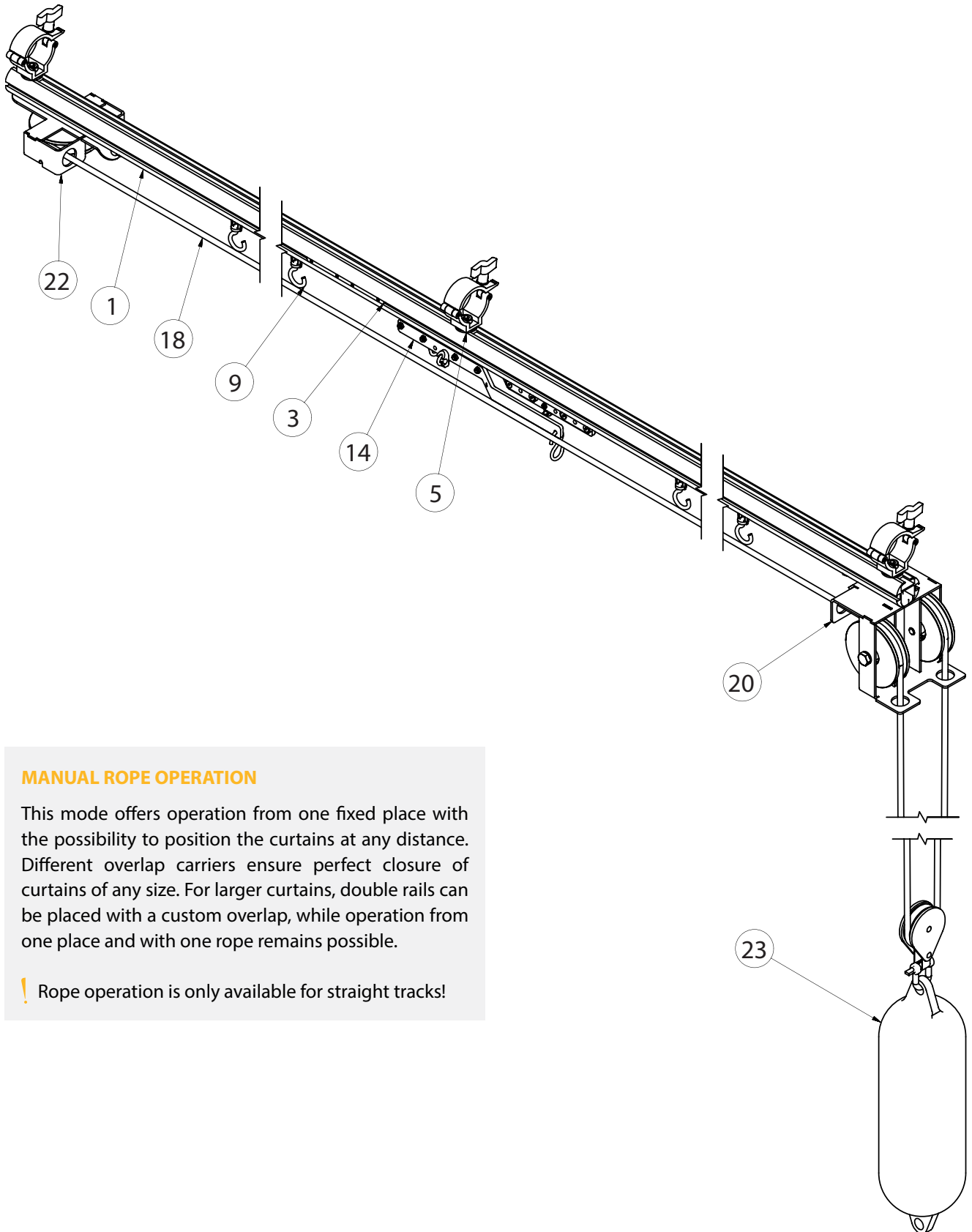

MANUAL ROPE OPERATION

This mode offers operation from one fixed place with the possibility to position the curtains at any distance. Different overlap carriers ensure perfect closure of curtains of any size. For larger curtains, double rails can be placed with a custom overlap, while operation from one place and with one rope remains possible.

! Rope operation is only available for straight tracks!

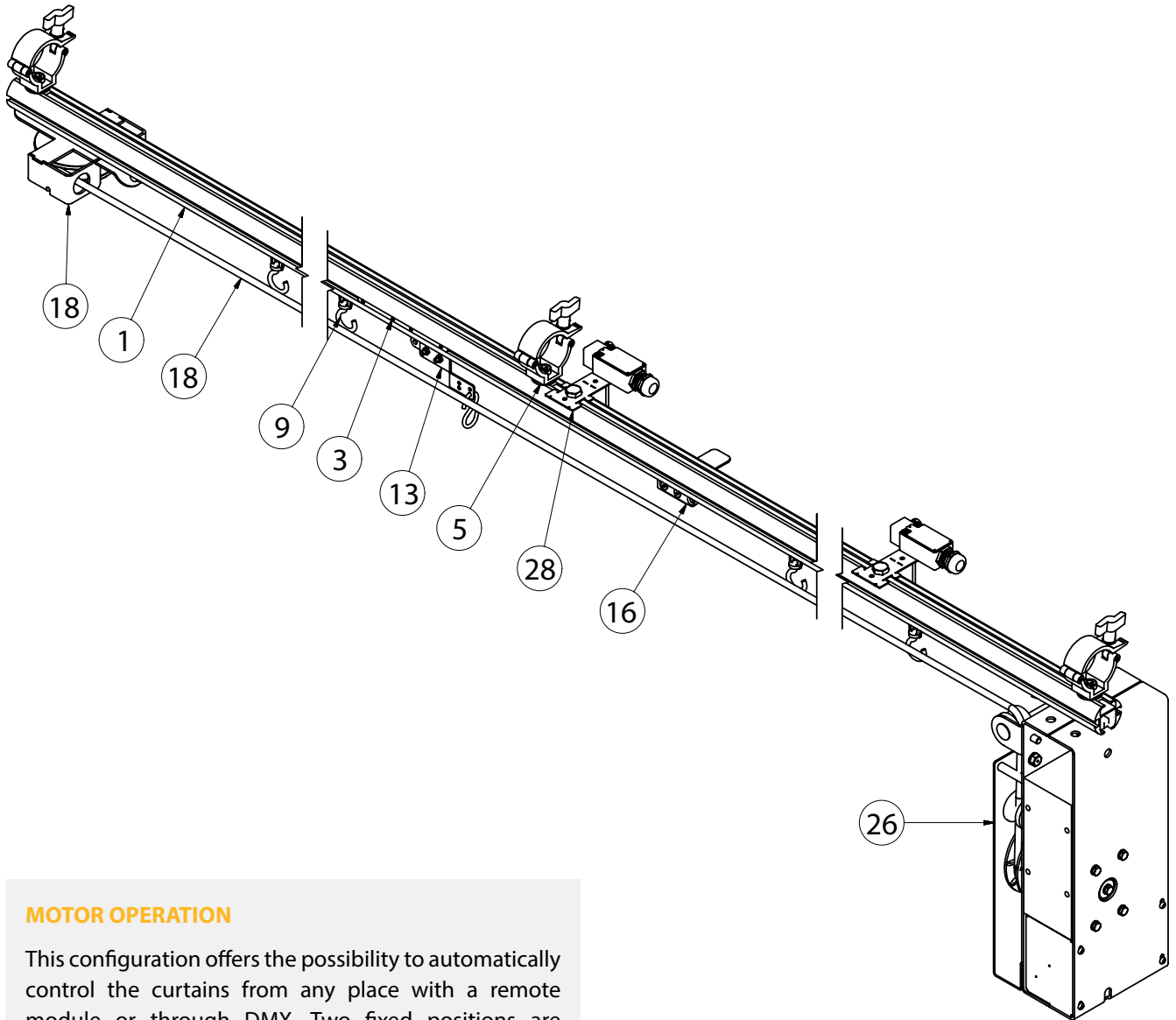

MOTOR OPERATION

This configuration offers the possibility to automatically control the curtains from any place with a remote module or through DMX. Two fixed positions are possible and, depending on the motor, variable speed control is also provided. Different overlap carriers ensure perfect closure of curtains of any size. For larger curtains, double rails can be placed with a custom overlap, while operation with one motor remains possible.

! Motor operation is only available for straight tracks!

» COMPONENTS (MM)

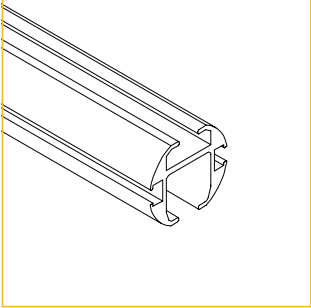
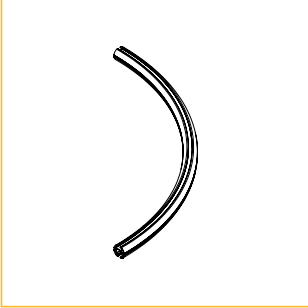
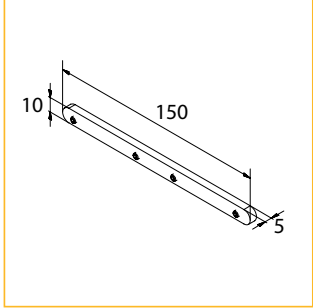
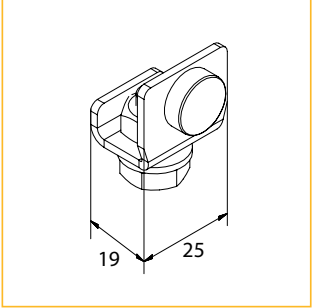
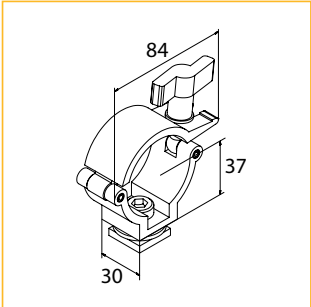
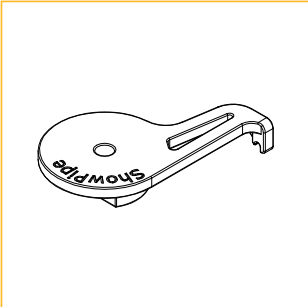
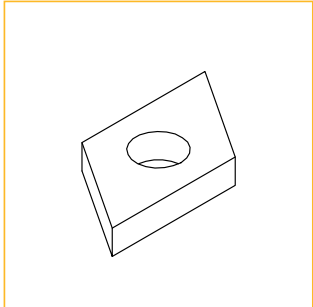
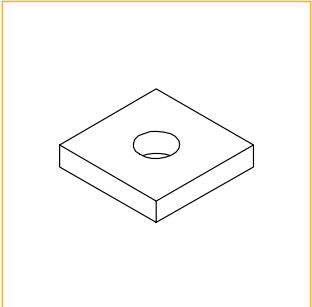
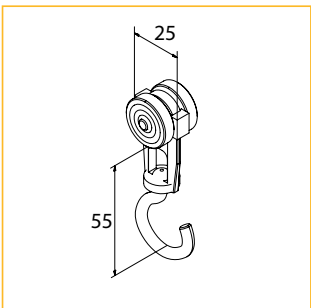
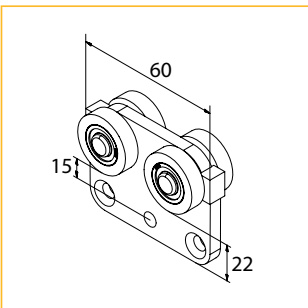
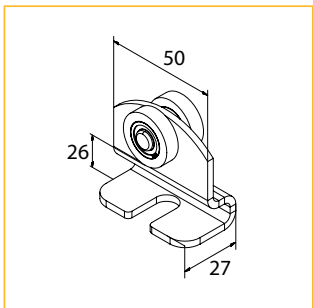
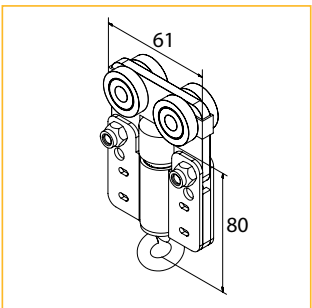
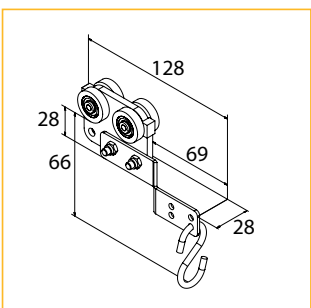
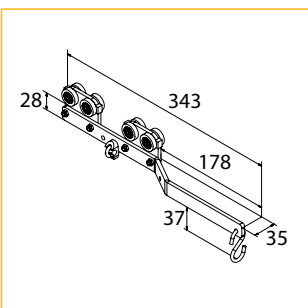
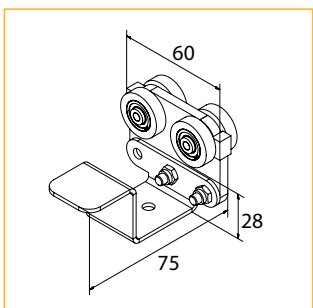
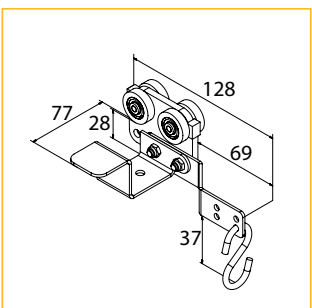
TRACK					
	1. Track	2. Curved Track	3. Joiner Set	4. End Stop	
	MOUNTING				
		5. Half Coupler Clamp	6. Hidden Ceiling Clip	7. Diamond Shaped Nut	8. Square Channel Nut
RUNNERS					
		9. Ball Raced Runner	10. Ball Raced Master Carrier	11. Scenery Carrier	12. Master Carrier with Brake
					
	13. Short Overlap Carrier	14. Overlap Carrier Set	15. Master Carrier for Motor Control	16. Short Overlap Carrier for Motor Control	

» COMPONENTS (MM)

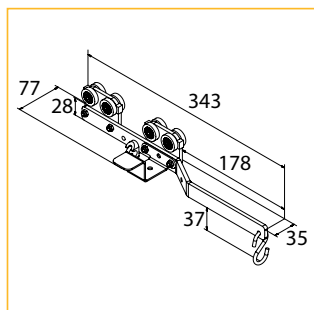

17. Overlap Carrier Set for Motor Control

OPERATION

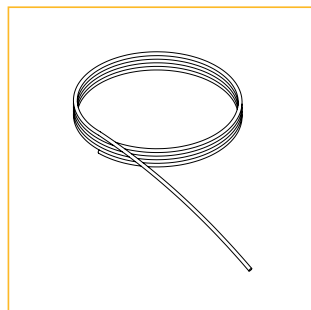

18. Double Braided Rope (Ø8 mm)

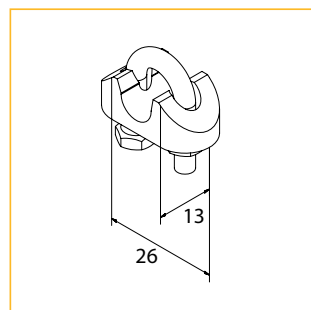

19. Rope Clamp (set of 3)

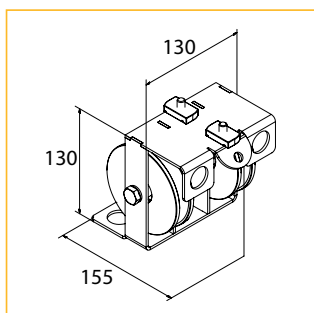

20. Head Pulley

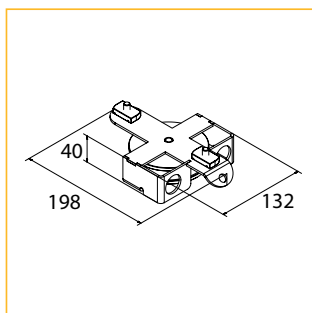

22. Return Pulley

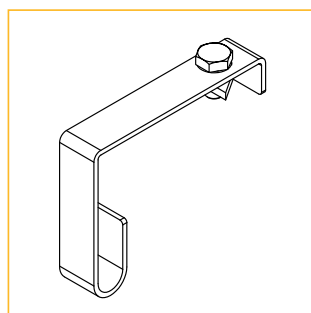

21. Line Pickup

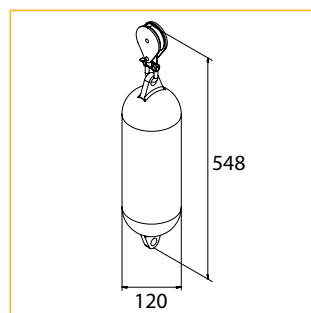

23. Weighted Return Pulley

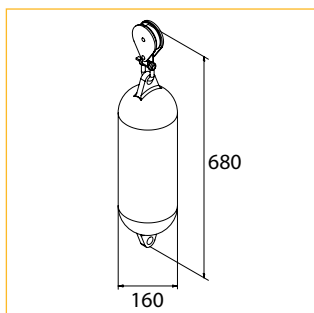

24. Weighted Return Pulley XL

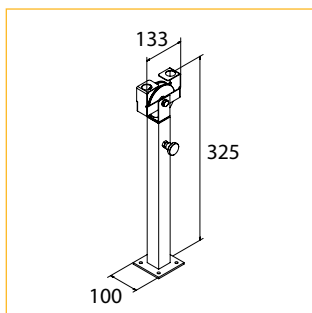

25. Floor Fixed Return Pulley

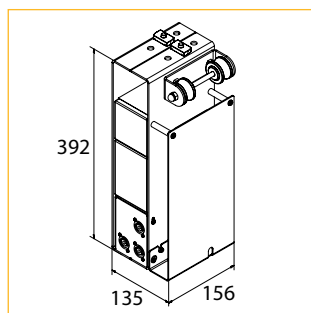

26. RTD 1000

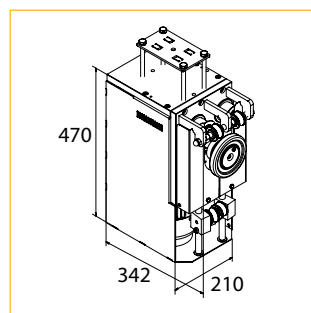

27. RTD 3000

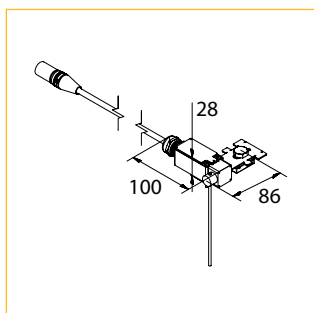

28. Limit Switch Set

» COMPONENTS

Name		Article code	Colour	Weight
1. Track (6m)		8055 0001 6007	Black	1.31 kg/meter
	45°, R 75 cm	8055 0004 0757	Black	1.54 kg/piece
	45°, R 100 cm	8055 0004 1007	Black	2.06 kg/piece
2. Standard Curved Track	90°, R 50 cm	8055 0007 0507	Black	1.54 kg/piece
	90°, R 75 cm	8055 0007 0757	Black	1.54 kg/piece
	90°, R 100 cm	8055 0007 1007	Black	2.06 kg/piece
Custom Curved Track	R _{min} 45 cm	8055 0007 0017	Black	Varies
3. Joiner Set		8055 0042 1507	Black	0.11 kg/set
4. End Stop		8050 0050 0001	Galvanised	0.03 kg/piece
5. Half Coupler Clamp		8055 0680 0757	Black	0.40 kg/piece
6. Hidden Ceiling Clip		8055 0110 0017	Black	0.004 kg/piece
7. Diamond-Shaped Nut		8700 9224 0011	Inox	0.01 kg/piece
8. Square Channel Nut		8055 9224 0007	Galvanised	0.02 kg/piece
9. Ball Raced Runner		8050 0205 0083 8050 0205 0087	White Black	0.03 kg/piece 0.03 kg/piece
10. Ball Raced Master Carrier		8050 0221 0163 8050 0221 0167	White Black	0.05 kg/piece 0.05 kg/piece
11. Scenery Carrier		8055 0230 0002	Galvanised with plastic wheels	0.11 kg/piece
12. Master Carrier with Brake		8050 0221 0197	Black	0.05 kg/piece
13. Short Overlap Carrier		8050 0245 0053 8050 0245 0057	White Black	0.09 kg/piece 0.09 kg/piece
14. Overlap Carrier Set		8050 0246 0167	Black	0.82 kg/set
15. Master Carrier for Motor Control		8050 0228 0163 8050 0228 0167	White Black	0.116 kg/piece 0.116 kg/piece
16. Short Overlap Carrier for Motor Control		8050 0245 1057	Black	0.09 kg/piece
17. Overlap Carrier Set for Motor Control		8050 0246 0157	Black	0.82 kg/set
18. Double Braided Rope (Ø8 mm)		7530 0308 0007	Black	0.04 kg/meter
19. Rope Clamp (set of 3)		8050 0248 0035	Galvanised	0.035 kg/piece
20. Head Pulley		8050 0400 0037	Black	1.65 kg/piece
21. Return Pulley		8050 0410 0037	Black	0.95 kg/piece
22. Line Pickup		8055 0694 0007	Black	0.2 kg/piece
23. Weighted Return Pulley		8050 0415 0057	Black	5.50 kg/piece
24. Weighted Return Pulley XL		8050 0415 0087	Black	10.50 kg/piece
25. Floor Fixed Return Pulley		8050 0420 0007	Black	3.38 kg/piece
26. RTD1000		8050 0713 2207	Black/Aluminum	11.8 kg/piece
27. RTD3000		8050 0743 3707	Black/Aluminum	37.2 kg/piece
28. Limit Switch Set		8050 0770 0010	Black/Green	0.226 kg/set

* Custom colours on demand.

HAVE A GREAT SHOW!
MORE INFO ON WWW.SHOWTEX.COM