

RAIL H100

TECHNICAL DATA SHEET

June 2020

Rail H100 is a multifunctional, budget-friendly curtain track for medium-heavy to heavy curtains.

» TRACK DIMENSIONS (MM)

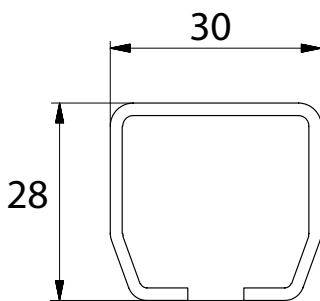

Track weight	1.34 kg/m
Track section max length	6 m
Curved track min radius	0.2 m

» SPECIFICATIONS

- The H100 is a steel track, standard available in three different finishes galvanized, with a white (RAL 9016) or black coating (RAL 9005). Custom colours are available on demand.
- Rails are available in straight lengths or curved to your specific tions. Couplers are available to join straight as well as curved rails.
- Mounting options include a wide range of different fi tures, offering a huge variety of application areas.
- A H100 system can be operated:
Manually: walking along the track or by pull-cord operation
Automatically: by pull-cord operation with our RTD series motors
- Different types of runners are available to answer a broad range of possible needs, including ball raced runners, scenery carriers, master carriers with brakes and overlap carriers.

» LOAD CAPACITY TRACK

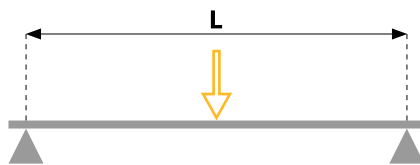

L (m)	Point load (kg)
1	73 kg
1.5	61 kg

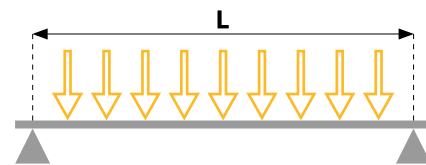

L (m)	Uniformly distributed load (kg/m) • total resulting load (kg)
1	150 kg/m • 150 kg
1.5	75 kg/m • 112 kg

! The distance between two supports should not exceed 1.5 m

The stated load capacities apply to the rail only. The load bearing capacity of the carrying construction (ceiling/truss/...) and all individual mounting accessories must be taken into account as well.

Load capacities have been calculated using Safety Factor 2. Apply the required Safety factor according to the standards pertaining to your application.

» TRACK DIMENSIONS ACCORDING TO CURTAIN SIZE (MM)

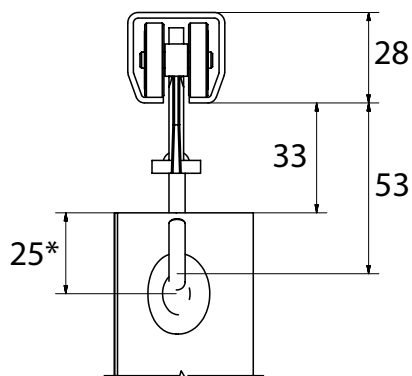

* standard distance for grommet

» RUNNER INFORMATION

Name	Article code	SWL	MIN. RADIUS OF BENDED RAIL
Ball raced runner	8050 0205 0087	8 kg	205 mm
Master carrier	8050 0221 0167	15 kg	205 mm
Scenery carrier	8050 0230 0302	60 kg	205 mm
Master carrier with brake	8050 0221 0197	15 kg	205 mm
Short overlap carrier	8050 0245 0057	15 kg	205 mm
Long overlap carrier set	8050 0246 0167	15 kg	2000 mm
Master carrier for motor control	8050 0228 0167	15 kg	n.a.
Short overlap carrier for motor control	8050 0245 1057	15 kg	n.a.
Overlap carrier set for motor control	8050 0246 1167	15 kg	n.a.

» ASSEMBLIES

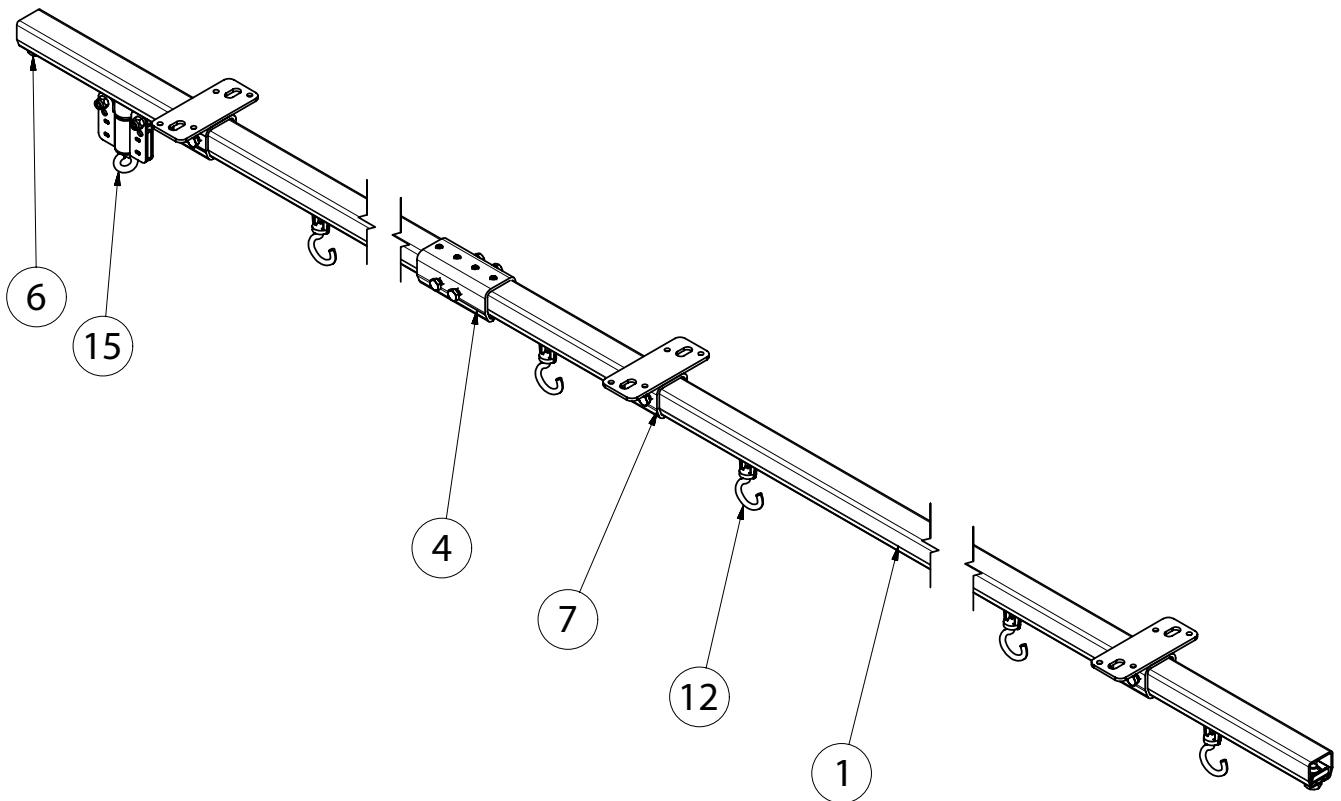

WALK-ALONG OPERATION

This is the most basic installation of the H100 system. The curtain is pulled along the rail to its required position. Optional braked master carriers make positioning more accurate.

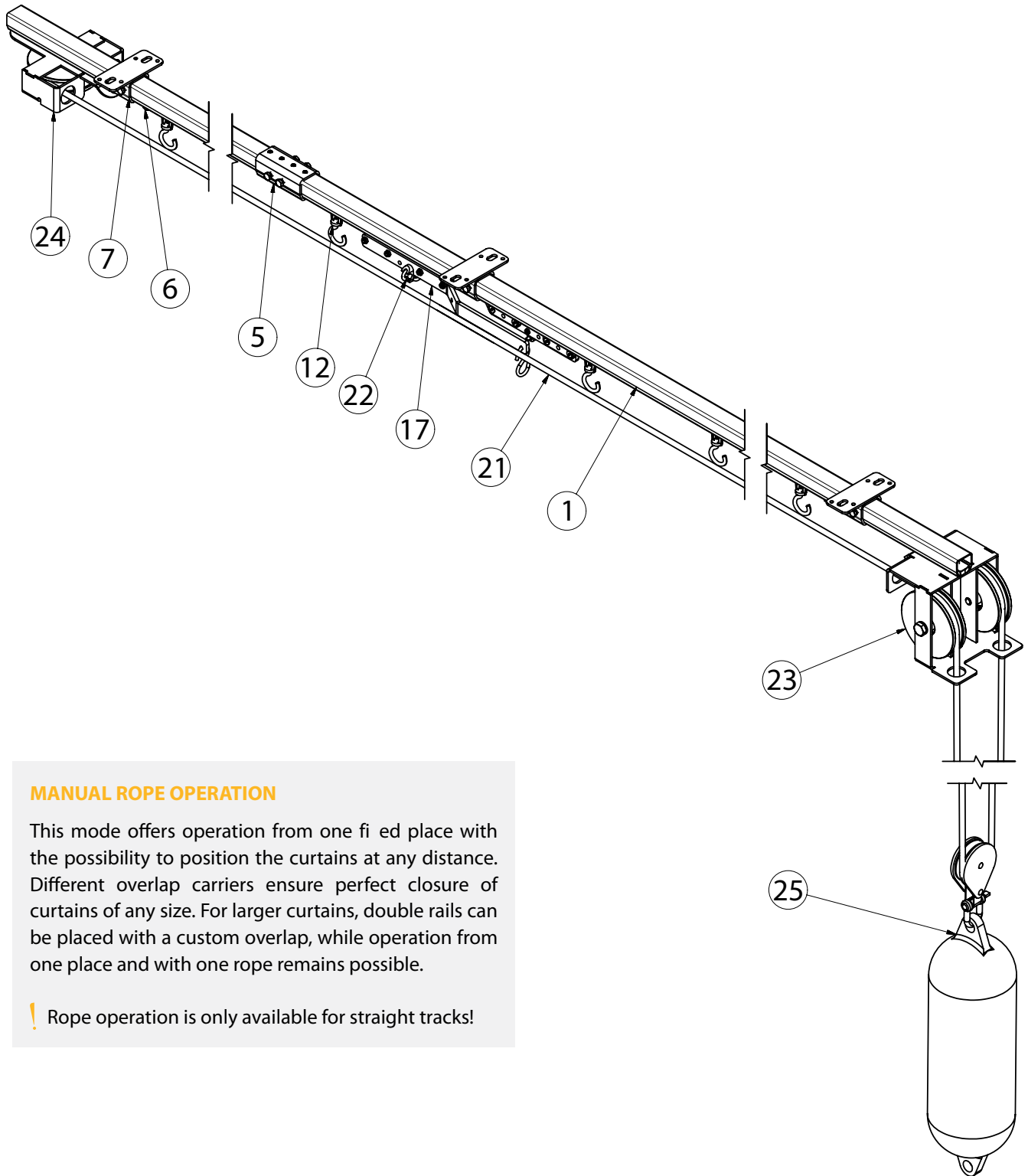

MANUAL ROPE OPERATION

This mode offers operation from one fixed place with the possibility to position the curtains at any distance. Different overlap carriers ensure perfect closure of curtains of any size. For larger curtains, double rails can be placed with a custom overlap, while operation from one place and with one rope remains possible.

! Rope operation is only available for straight tracks!

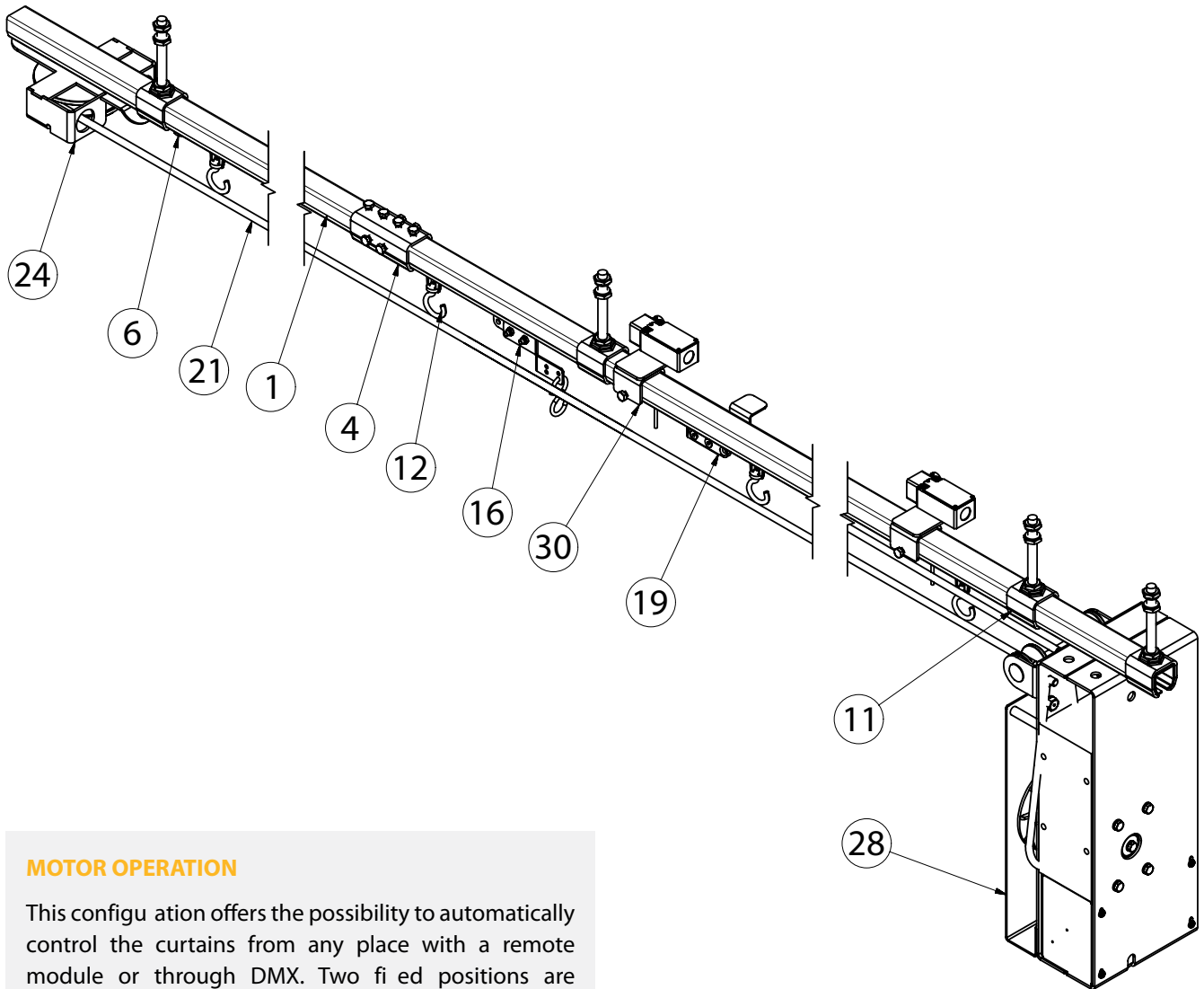

MOTOR OPERATION

This configuration offers the possibility to automatically control the curtains from any place with a remote module or through DMX. Two fixed positions are possible and, depending on the motor, variable speed control is also provided. Different overlap carriers ensure perfect closure of curtains of any size. For larger curtains, double rails can be placed with a custom overlap, while operation with one motor remains possible.

! Motor operation is only available for straight tracks!

» COMPONENTS (MM)

TRACK

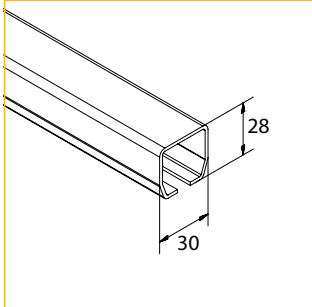

1. Track

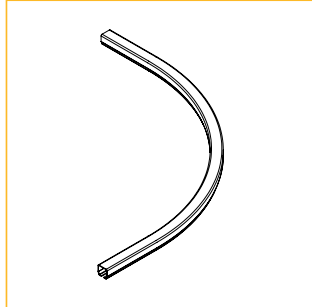

2 + 3. Curved Track

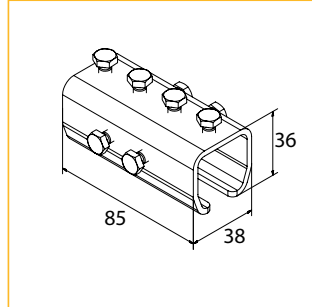

4. Coupling

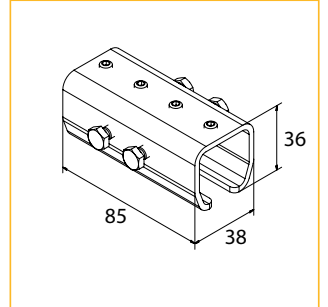

5. Coupling for use with Ceiling Brackets

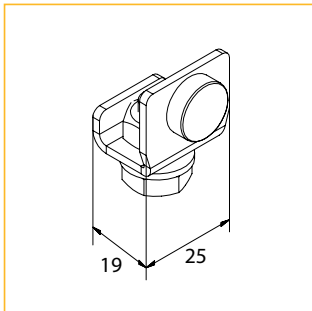

6. End Stop

MOUNTING

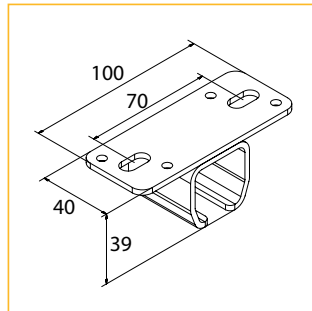

7. Ceiling Bracket

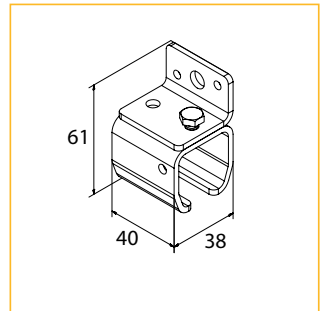

8. Wall Bracket

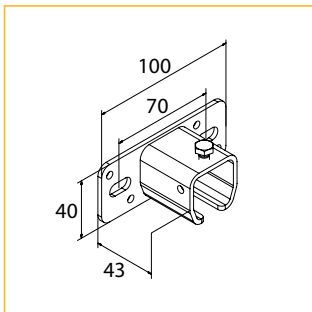

9. Horizontal Wall Bracket

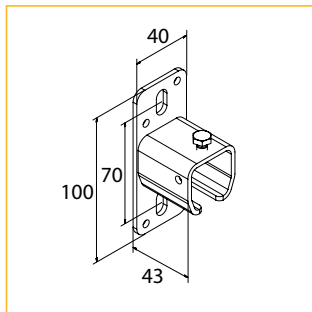

10. Vertical Wall Bracket

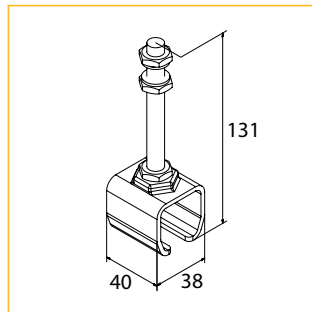

11. Bracket + M10 Studding

RUNNERS

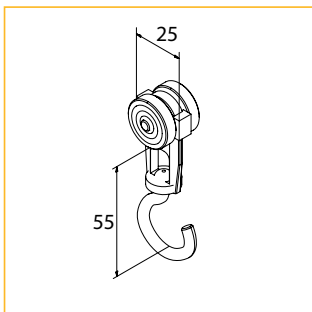

12. Ball Raced Runner

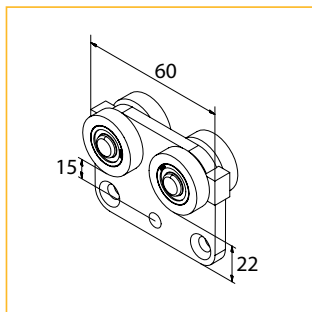

13. Ball Raced Master Carrier

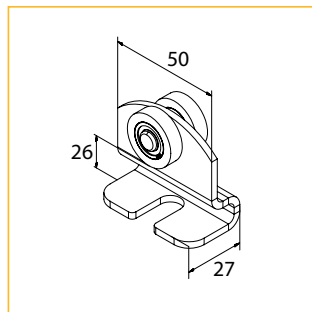

14. Scenery Carrier

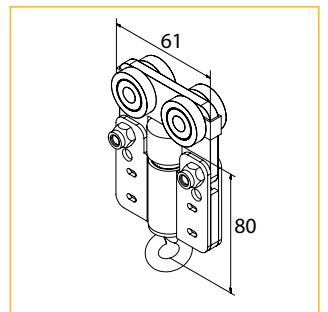

15. Master Carrier with Brake

» COMPONENTS (MM)

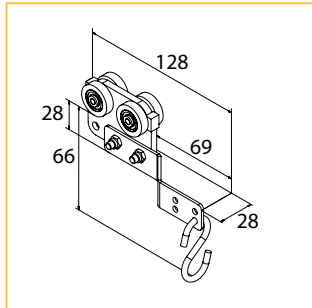

16. Short Overlap Carrier

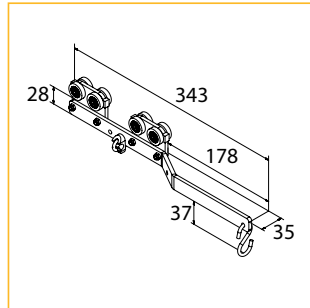

17. Overlap Carrier Set

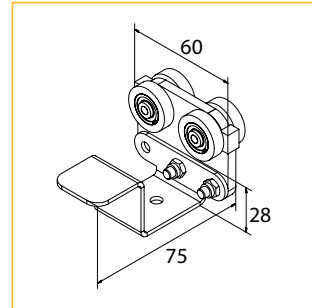

18. Master Carrier for Motor Control

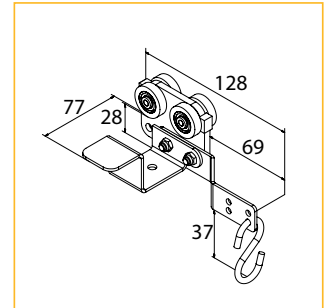

19. Short Overlap Carrier for Motor Control

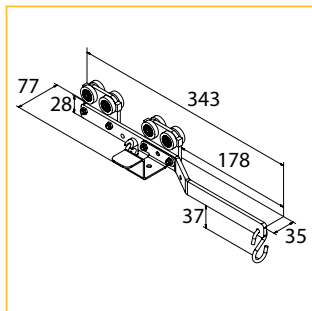

20. Overlap Carrier Set for Motor Control

OPERATION

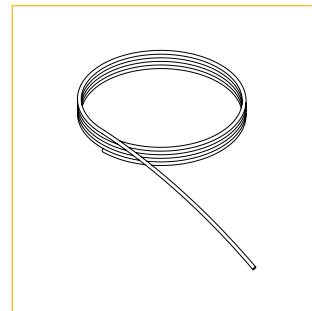

21. Double Braided Rope

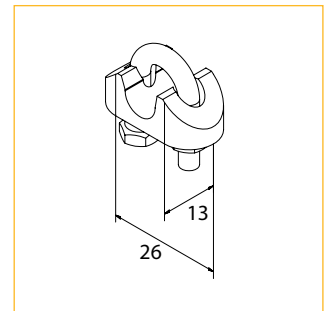

22. Rope Clamp

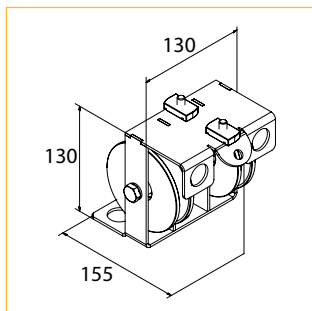

23. Head Pulley

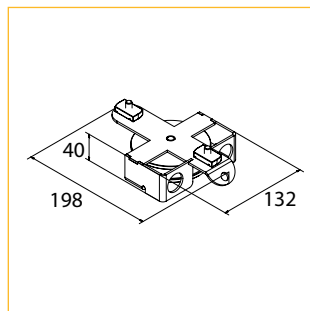

24. Return Pulley

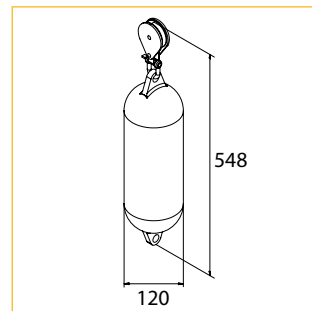

25. Weighted Return Pulley

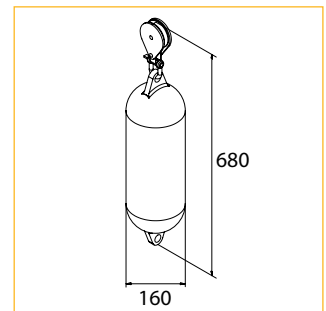

26. Weighted Return Pulley XL

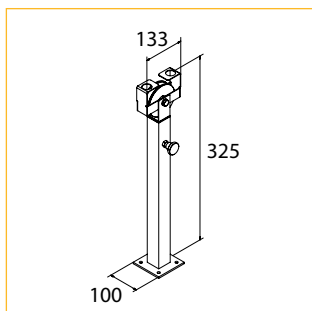

27. Floor Fixed Return Pulley

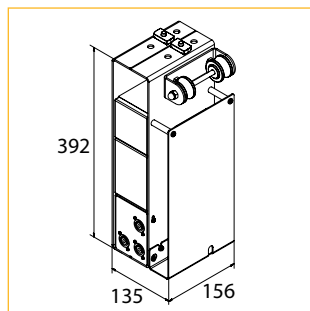

28. RTD 1000

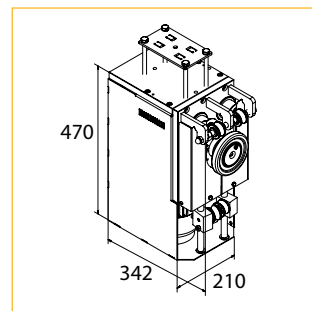

29. RTD 3000

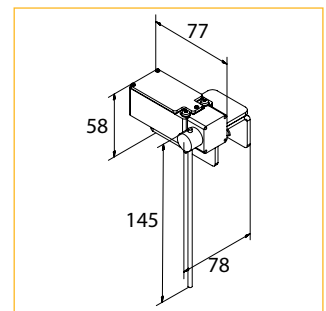

30. Limit Switch Set

» COMPONENTS

Name	Article code	Colour	Weight
1. Track (6m) *	8050 0001 6001 8050 0001 6007	Galvanised Black	1.34 kg/meter
	45°, R 65 cm	Galvanised Black	1.85 kg/piece
	45°, R 100 cm	Galvanised Black	2.66 kg/piece
	90°, R 20.5 cm	Galvanised White Black	1.93 kg/piece
	90°, R 30 cm	Galvanised Black White	1.92 kg/piece
	2. Standard Curved Track *	90°, R 40 cm	Galvanised Black
90°, R 50 cm		Galvanised Black	2.48 kg/piece
90°, R 65 cm		Black Galvanised	2.10 kg/piece
90°, R 100 cm		Galvanised Black	4.88 kg/piece
90°, R 200 cm		Galvanised Black	5.10 kg/piece
3. Custom Curved Track *		23.5 cm < R < 200 cm	Galvanised
	23.5 cm < R < 200 cm	White	Varies
	23.5 cm < R < 200 cm	Black	Varies
	R > 200 cm	Galvanised	Varies
	R > 200 cm	White	Varies
	R > 200 cm	Black	Varies
4. Coupling *	8050 0040 0801 8050 0040 0803 8050 0040 0807	Galvanised White Black	0.24 kg/piece
	8050 0040 0811 8050 0040 0817	Galvanised Black	0.24 kg/piece
	8050 0050 0001	Galvanised	0.03 kg/piece
6. End Stop	8050 0110 0001 8050 0110 0003 8050 0110 0007	Galvanised White Black	0.18 kg/piece
7. Ceiling Bracket *	8050 0100 0001 8050 0100 0007	Galvanised Black	0.14 kg/piece
8. Wall Bracket *	8050 0100 0037	Black	0.14 kg/piece
9. Horizontal Wall Bracket *	8050 0100 0057	Black	0.14 kg/piece
10. Vertical Wall Bracket *	8050 0130 0101 8050 0130 0103 8050 0130 0107	Galvanised White Black	0.18 kg/piece
11. Bracket + M10 Studding *	8050 0205 0083 8050 0205 0087	White Black	0.03 kg/piece
12. Ball Raced Runner			

* Custom colours on demand.

» **COMPONENTS**

Name	Article code	Colour	Weight
13. Ball Raced Master Carrier	8050 0221 0163 8050 0221 0167	White Black	0.05 kg/piece
14. Scenery Carrier	8055 0230 0001	Galvanised	0.20 kg/piece
15. Master Carrier with Brake	8050 0221 0197	Black	0.05 kg/piece
16. Short Overlap Carrier	8050 0245 0053 8050 0245 0057	White Black	0.09 kg/piece
17. Overlap Carrier Set	8050 0246 0167	Black	0.82 kg/piece
18. Master Carrier for Motor Control	8050 0228 0163 8050 0228 0167	White Black	0.116 kg/piece
19. Short Overlap Carrier for Motor Control	8050 0245 1057	Black	0.09 kg/piece
20. Overlap Carrier Set for Motor Control	8050 0246 1167	Black	0.82 kg/set
21. Double Braided Rope (Ø 8 mm)	7530 0308 1007	Black	0.04 kg/meter
22. Rope Clamp (set of 3)	8050 0248 0035	Galvanised	0.035 kg/piece
23. Head Pulley	8050 0400 0037	Black	1.65 kg/piece
24. Return Pulley	8050 0410 0037	Black	0.95 kg/piece
25. Weighted Return Pulley	8050 0415 0057	Black	5.50 kg/piece
26. Weighted Return Pulley XL	8050 0415 0087	Black	10.50 kg/piece
27. Floor Fixed Return Pulley	8050 0420 0007	Black	3.38 kg/piece
28. RTD1000	8050 0713 2207	Black/Aluminum	11.8 kg/piece
29. RTD3000	8050 0743 3707	Black/Aluminum	37.2 kg/piece
30. Limit Switch Set	8050 0770 0010	Black/Green	0.226 kg/set

HAVE A GREAT SHOW!
MORE INFO ON WWW.SHOWTEX.COM