

WIDESCREEN 600 BIG

WIDESCREEN 600 BIG

Permanently installed large size system



WIDESCREEN 600 is a permanently installed large venue projection screen system.

Available in standard sizes with viewing area base from 700 cm up to 850 cm 276 - 335 inches (w).

Available format: 16:9 - 16:10 - 4:3. The system is ideal for very large, permanently installed applications.

OPTIONS:

- Total white without borders
- Black borders (5cm)
- Tensioned
- White tensioned

WIDESCREEN 600 BIG

Permanently installed large size system

Total white without borders:

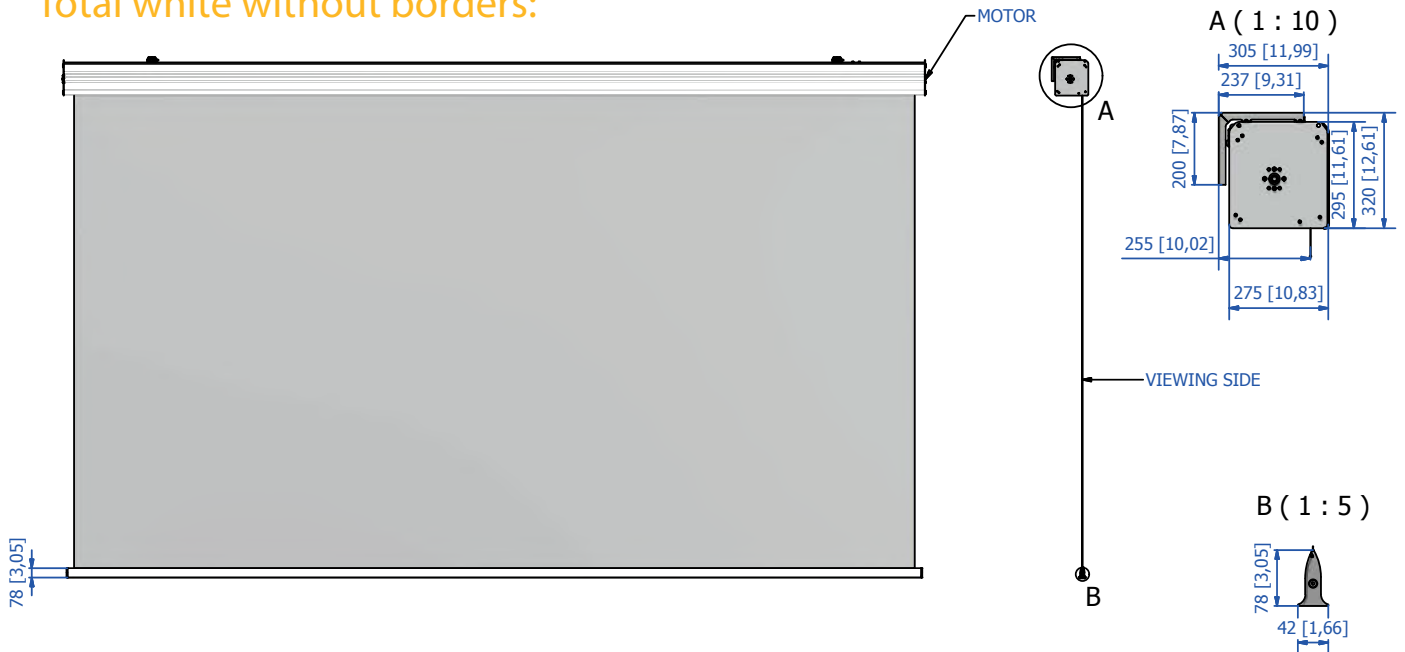

Available sizes chart:

	4:3		16:10		16:9		Encumbrance	kg
Mod	B x H (cm)	D	B x H (cm)	D	B x H (cm)	D	L (cm)	kg
700	700 x 525	344"	700 x 437	325"	700 x 393	339"	718	144
750	750 x 562	369"	750 x 469	348"	750 x 422	339"	768	155
800	800 x 600	394"	800 x 500	371"	800 x 450	361"	818	166
850	850 x 638	418"	850 x 531	395"	850 x 478	384"	868	177

WIDESCREEN 600 BIG



Permanently installed large size system

Black borders:

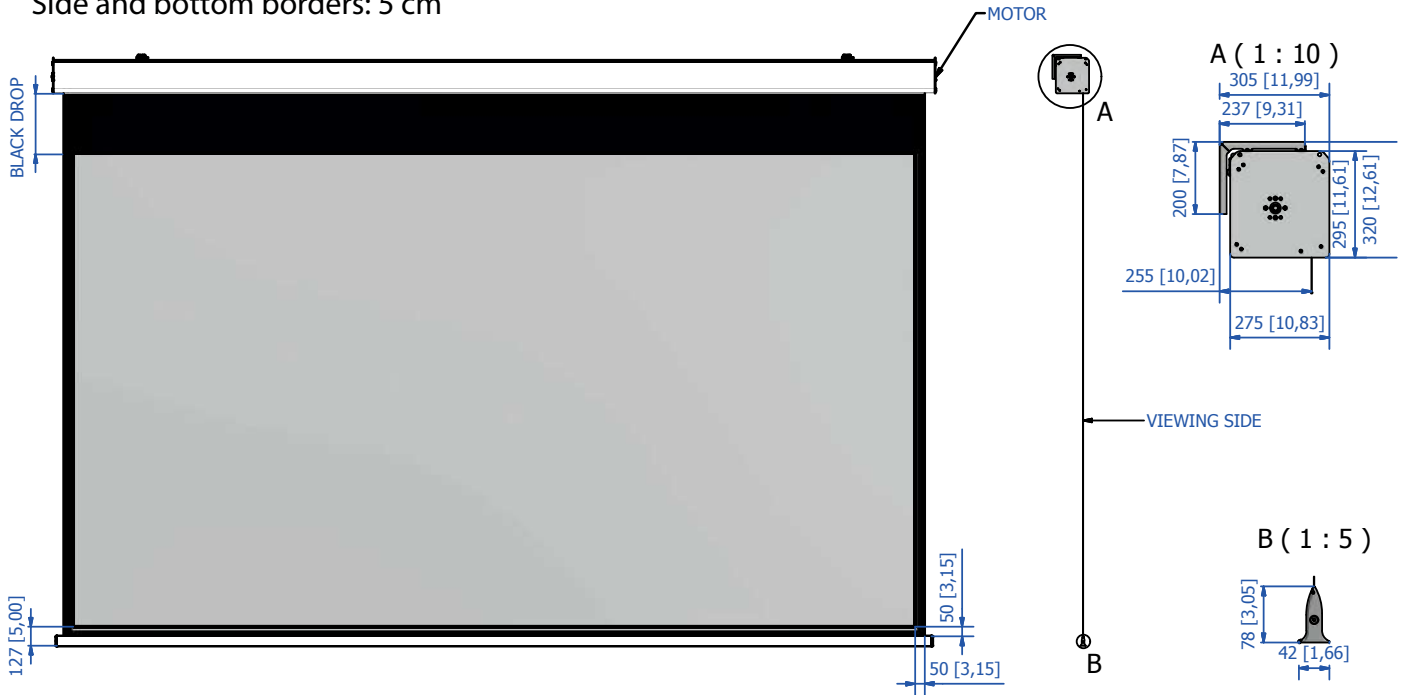
Side and bottom borders: 5 cm

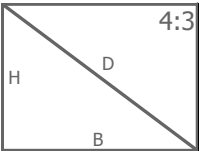
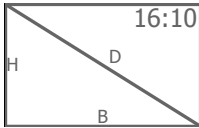
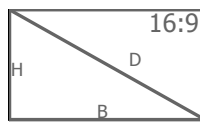

Available sizes chart: Black borders

	 4:3 BLACK DROP 20 cm		 16:10 BLACK DROP 35 cm		 16:9 BLACK DROP 50 cm		 Encumbrance	 kg
Mod	B x H (cm)	D	B x H (cm)	D	B x H (cm)	D	L (cm)	kg
690	690 x 517	340"	690 x 431	320"	690 x 388	312"	718	144
740	740 x 555	364"	740 x 462	344"	740 x 416	334"	768	155
790	790 x 592	389"	790 x 493	367"	790 x 444	357"	818	166
840	840 x 630	413"	840 x 525	390"	840 x 472	379"	868	177



WIDESCREEN 600 BIG

Permanently installed large size system

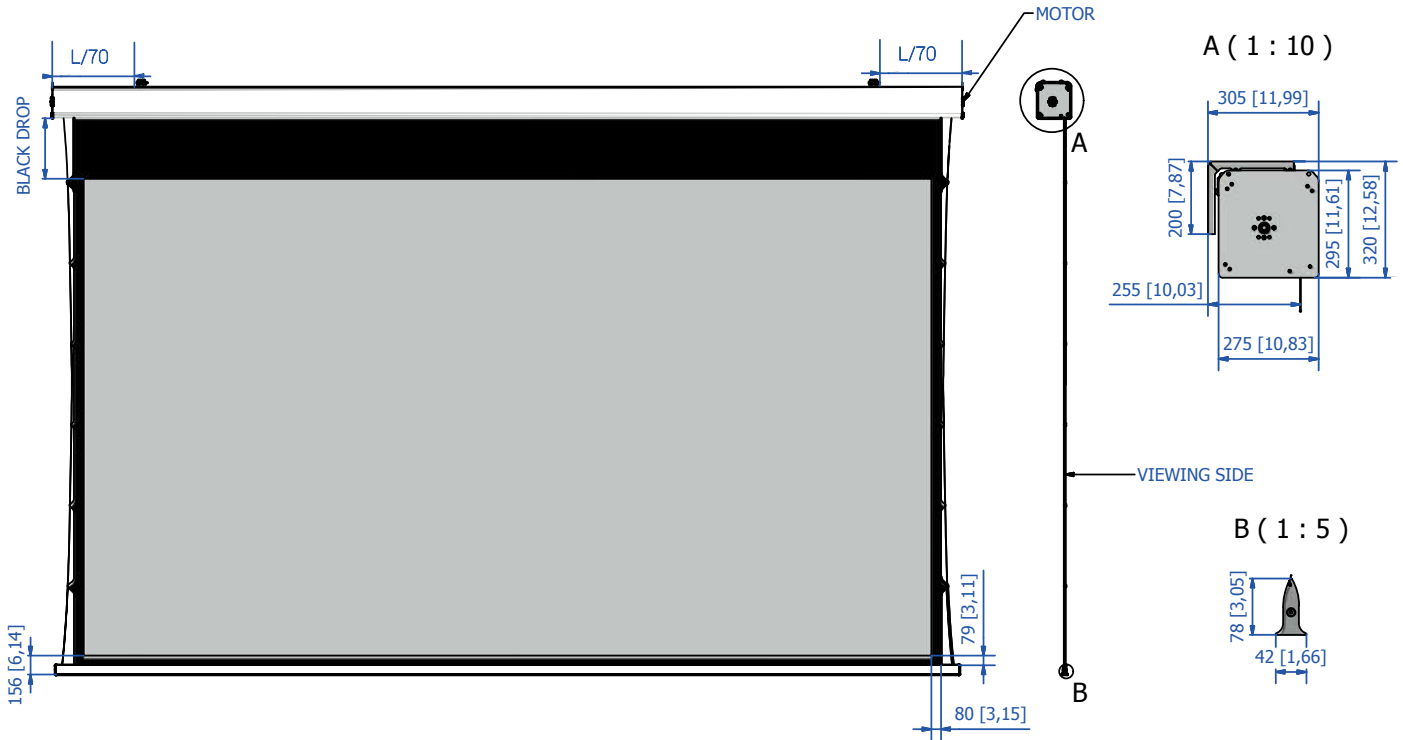
Tensioned

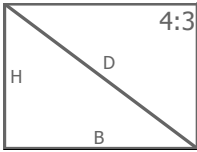
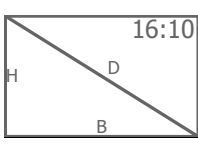
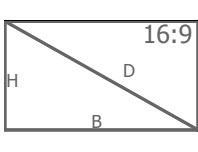
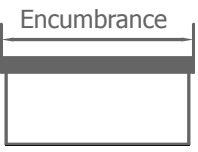

Available sizes chart: Tensioned

	 BLACK DROP 20 cm	 BLACK DROP 35 cm	 BLACK DROP 50 cm					
Mod	B x H (cm)	D	B x H (cm)	D	B x H (cm)	D	L (cm)	kg
670	670 x 502	340"	670 x 418	311"	670 x 418	303"	722	144
720	720 x 540	364"	720 x 450	334"	720 x 405	325"	772	155
770	770 x 577	389"	770 x 481	357"	770 x 433	348"	822	166
820	820 x 615	404"	820 x 512	381"	820 x 461	370"	872	177

WIDESCREEN 600 BIG

Permanently installed large size system

White tensioned:

Side white borders: 3,5 cm

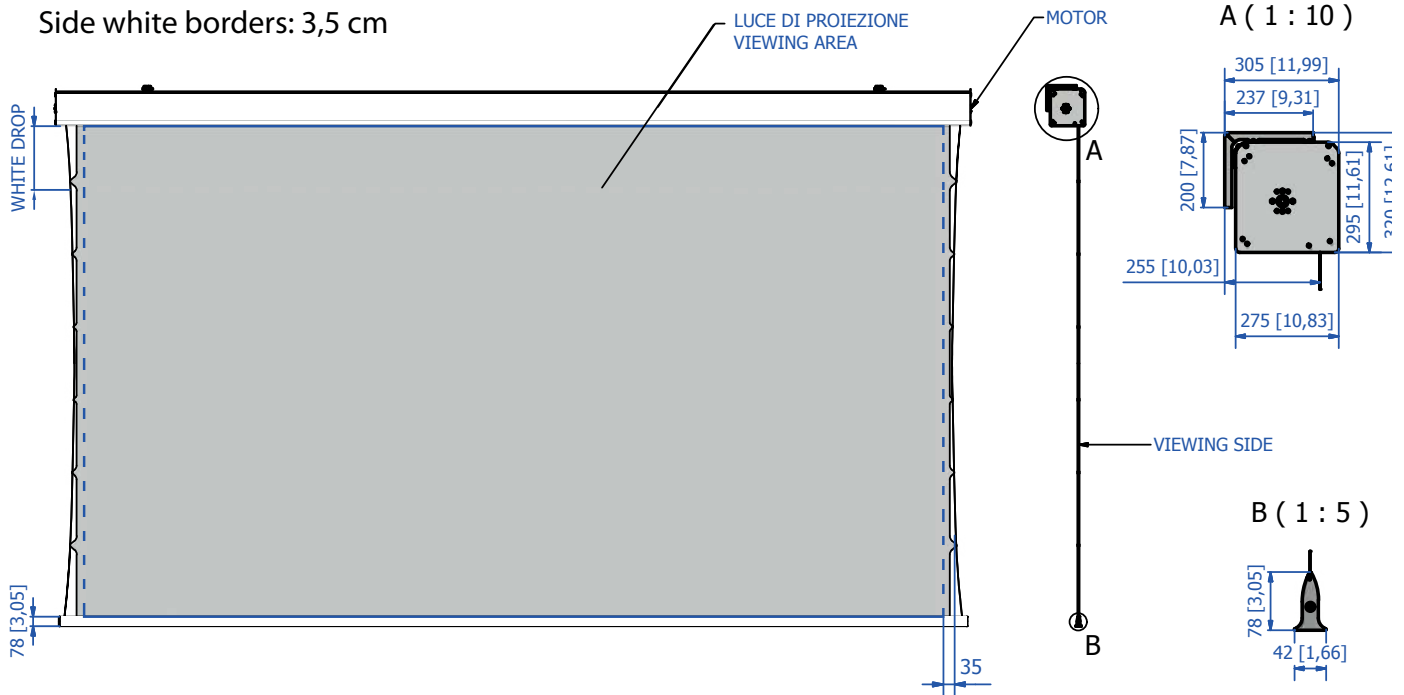

Available sizes chart: White tensioned

Mod	4:3		16:10		16:9		Encumbrance L (cm)	kg
	B x H (cm)	D	B x H (cm)	D	B x H (cm)	D		
700	700 x 525	344"	700 x 437	325"	700 x 393	303"	734	147
750	750 x 563	369"	750 x 469	348"	750 x 422	325"	784	158
800	800 x 600	394"	800 x 500	371"	800 x 450	348"	834	168
840	840 x 638	418"	840 x 525	395"	840 x 472	379"	874	180

WIDESCREEN 600 BIG

Permanently installed large size system



- Smart force measurement.
- Automatic block when counterweight is stuck in.
- Five year limited warranty.
- Limit switches are factory set guaranteeing a long life span.

Motor technical data and dimensions

Operating Voltage (V)	1 ~ 230
Frequency (Hz)	50
Noiseless soft brake	–
Fast-running version	–
Max. torque (Nm)	40
Speed (rpm)	14
Current (A)	1.2
Power (W)	270
Shaft Ø (mm)	50
Ingress protection (IP)	44
Max. limit switch range in Revolutions of the shaft	40
Operating mode (KB in min.)	5
Length A (mm)	540
Length B (mm)	522
Weight (kg)	2.6
Temperature range (°C)	– 20 to +60
Connecting cable pluggable (m)	2.0

WIDESCREEN 600 BIG

Permanently installed large size system

Wall and ceiling brack n. 2 units (included)

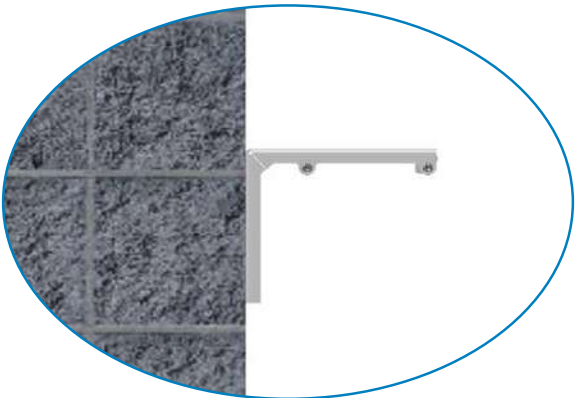
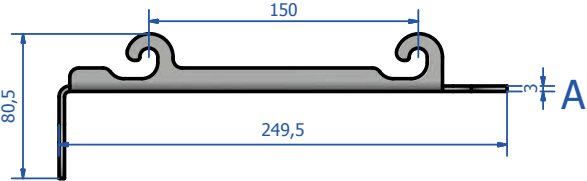
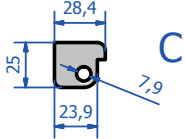
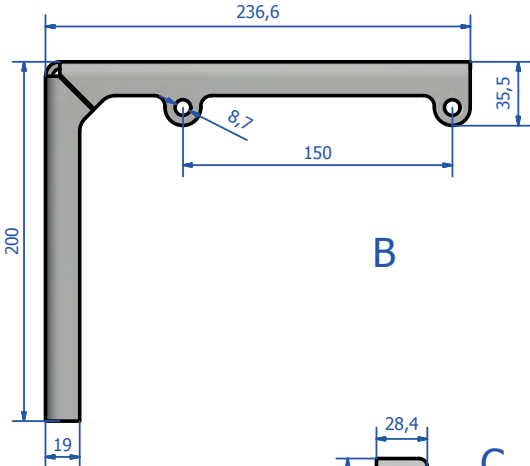
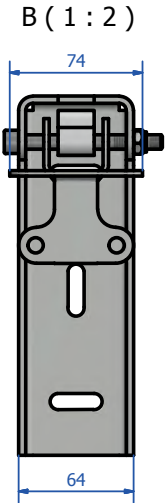
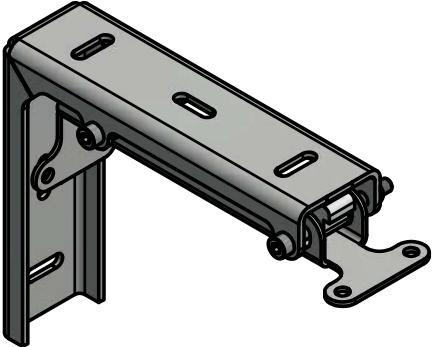
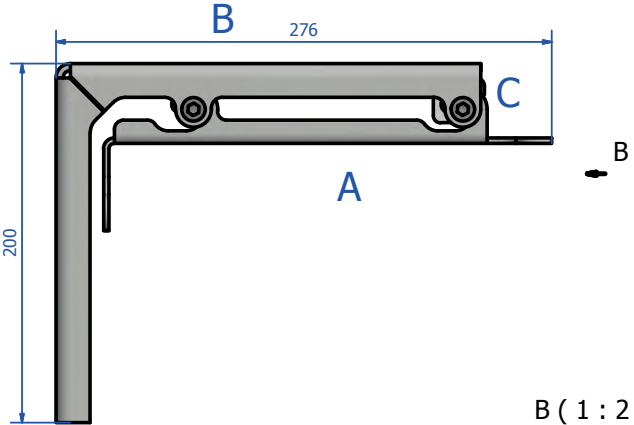

WIDESCREEN 600 BIG

Permanently installed large size system

Safety chains n. 2 units (included)

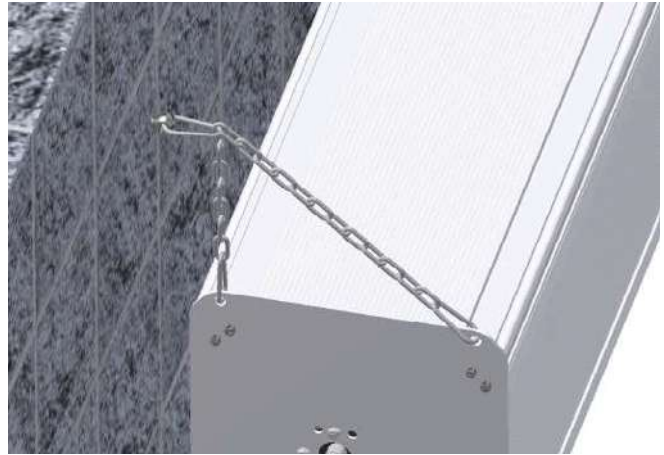
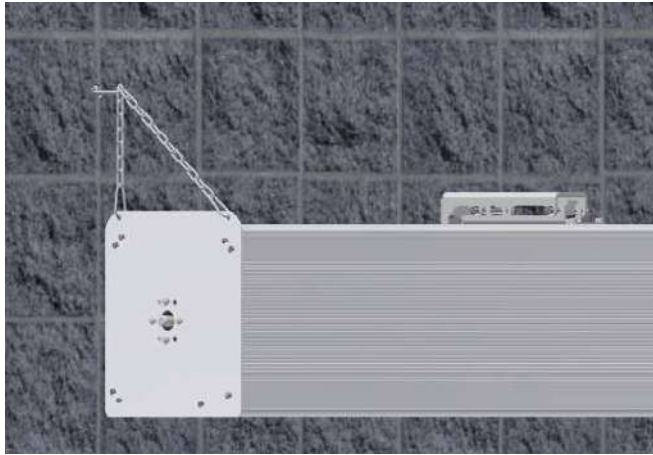

Easy quick regulation of the counterweight in case of waves on the fabric.

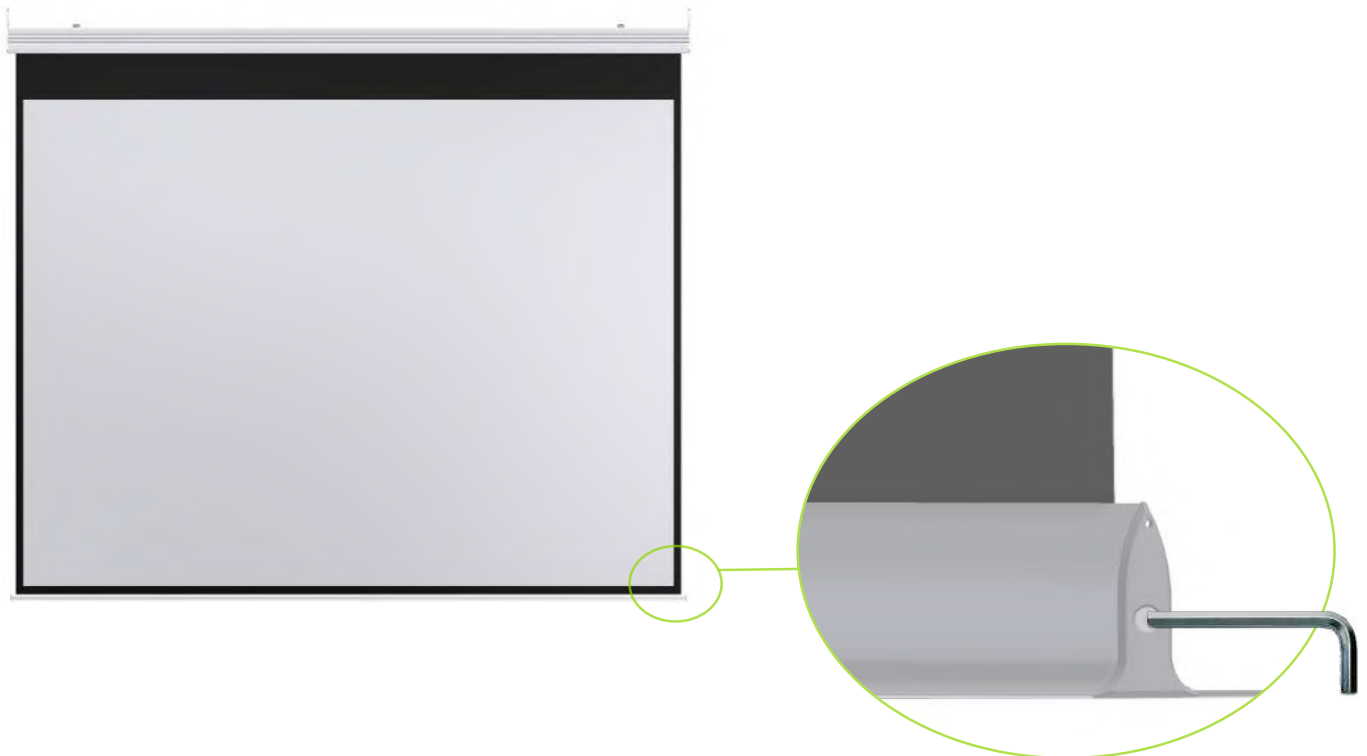

WIDESCREEN 600 BIG

Permanently installed large size system

Single control switch for an AC motor. Fixed position.



Controls available on request:

- RF VEGA Radio Frequency
The unit controls the motor as required by commands from the transmitter, or from a push-button that can be wired to the unit.

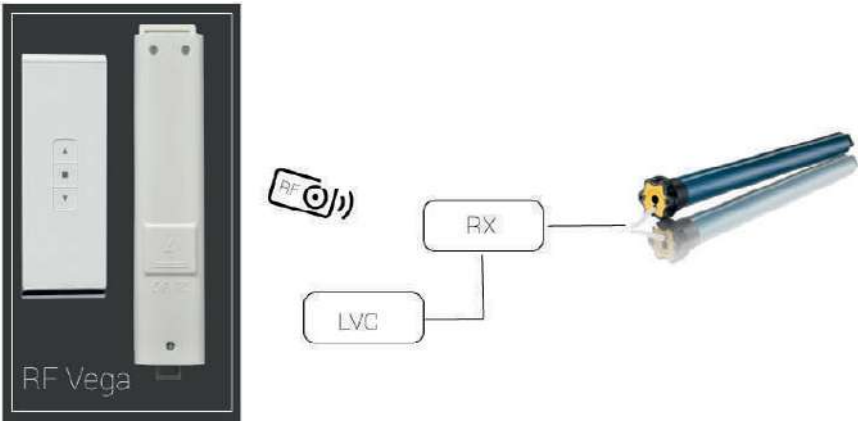

- IR VEGA Infrared control
The unit controls the motor as required by commands from the transmitter, or from a push-button that can be wired to the unit.

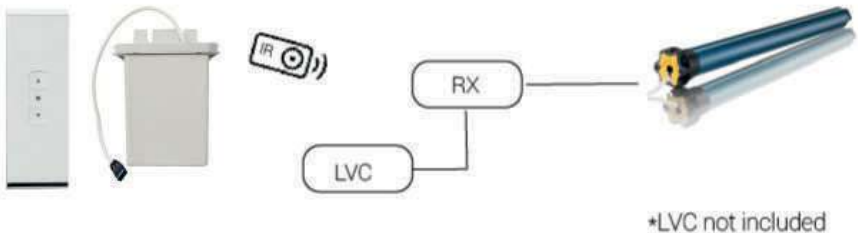

*LVC not included

WIDESCREEN 600 BIG

Permanently installed large size system

- KIT COMPLETE
(IR+RF+MANUAL SWITCH+CABLE TRIGGER)
A complete control:



- RTU + TRIGGER
The RTU, once connected to a video-projector 12v dc output, operates the screen downwards together with the projector switching on, thus the projector switching off sends the screen back up.



- RTU UNIVERSAL
Radio transmitter unit for videoprojectors. Designed to automatize the activation of videoprojection systems, the new RTU permits the synchronization of videoprojector and screen. It is provided with a transmitter which is connected to the power supply of the projector and a receiver which activates the screen. When the projector is switched on an impulse is sent to the receiver via radio frequency to lower the screen.

Similarly, when the projector is switched off a second impulse turns the screen off. The remote control provided also allows manual operations.



HAVE A GREAT SHOW!
MORE INFO ON WWW.SHOWTEX.COM